

APPARATUS FOR DETERMINATION OF LIQUID-LIQUID-GAS EQUILIBRIA AT ADVANCED PRESSURES

R. N. FLECK¹ AND J. M. PRAUSNITZ

Department of Chemical Engineering, University of California, Berkeley, Calif. 94720

A novel apparatus has been designed and built for studying liquid-liquid-gas equilibria. The experimental equipment features a new magnetic pump to recirculate all three phases, sampling from the recirculating streams, minimization of dead space, and analysis of all phases by gas chromatography. Typical operating pressures are up to about 1000 p.s.i.a. Special methods for sampling gases and liquids under pressure were developed.

IN CONNECTION with some initial experimental research on high-pressure vapor extraction, it was necessary to design and construct an apparatus for the determination of liquid-liquid-gas equilibria at higher pressures (50 to 1000 p.s.i.a.). Elgin and Weinstock (1959) had previously studied equilibria of this type. In the present work a new experimental approach was taken with a view toward using more recent techniques and instrumentation. Design criteria for the new apparatus included the following:

- Small liquid volumes
- High corrosion resistance
- Good temperature control
- Operation at pressures up to 1000 p.s.i.a.
- Magnetic pumping of all three phases
- Minimal dead space
- Sampling from flowing streams
- Analysis of all phases by gas chromatography

We describe here briefly the apparatus which we have designed and operated. A more complete description is available (Fleck, 1967).

Layout of Apparatus

Figure 1 shows a scale elevation view of the location of major components of the equilibrium apparatus.

All of the major vessels, valves, and lines were mounted on a rack made of 1-inch angle stock (stainless steel). The rack was submerged in the liquid-filled, constant-temperature bath as shown in Figure 1.

Gas Sampling

A linear valve consists of a bore fitted with ports and a loosely fitting shaft which mounts several O-rings to provide a series of seals between the shaft and the bore. To alter the flow of gas from one port to another through the annular space between the shaft and the bore, the shaft is pushed or pulled coaxially within the bore to alter the relative location of the seals with respect to the ports. Gas sampling in a gas chromatograph uses a six-port, two-position, linear valve where a loop between two ports is connected integrally between two other outer ports when the plunger is pulled out, and between the two innermost ports when the plunger is pushed in. By this means a sample of gas flowing to and from the outer ports can be injected into a carrier-gas stream flowing to and from the inner ports by simply pushing in the plunger.

¹ Present address, Union Oil Co., Brea, Calif. 92621

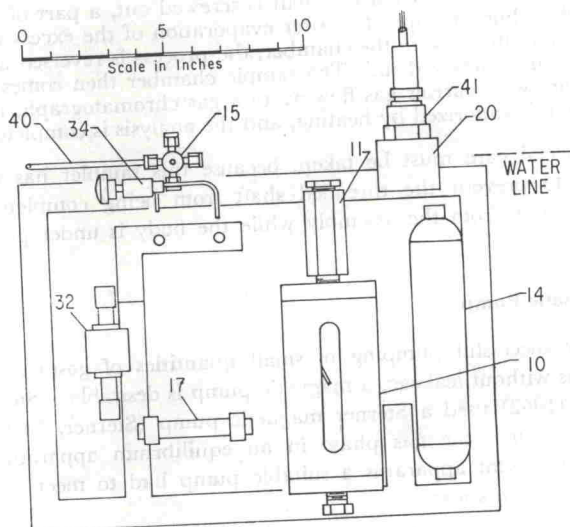

Figure 1. Elevation view of major components

- | | |
|-------------------------------|-------------------------|
| 10. Equilibrium cell | 20. Transducer receiver |
| 11. Safety head | 32. Magnetic pump |
| 14. Gas-surge vessel, 300 cc. | 34. Liquid sampler |
| 15. Linear valve | 40. Gas-sample loop |
| 17. Small gas-surge vessel | 41. Pressure transducer |

When this valve was used to sample a stream at higher pressures, the O-rings pushed out into the annulus provided for the gas flow, and leaks developed. A new shaft was machined which had a lip on either side of each O-ring, with backup rings on the two outermost O-ring seals. With this shaft O-ring failure did not occur at pressures of 1000 p.s.i.a. and an annular space was still available for the gas flow between ports.

After the pressure limitation of the linear valve had been solved, it became apparent that the gas-sample loop had to be heated somewhat above the equilibrium temperature of the system in order to obtain a representative gas sample. In the final design the linear valve was positioned above the constant-temperature bath and the gas-sample loop was wrapped with an insulated electric heating tape to provide the necessary heating.

Liquid Sampling

The liquid-sampling device is shown in an exploded view in Figure 2.

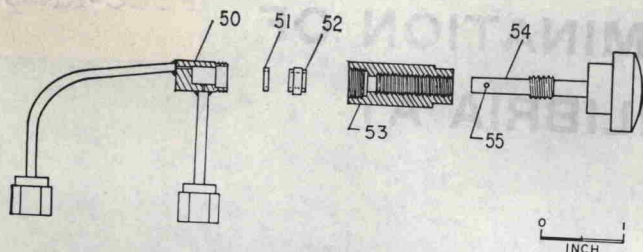

Figure 2. Liquid sampler

- 50. Body
- 51. Retaining washer
- 52. Plastic seal
- 53. Cap
- 54. Threaded shaft
- 55. Sample chamber (small hole drilled diametrically through cylindrical end of threaded shaft, 54)

The liquid flows upward into the body, 50, and out the top. A threaded shaft, 54, has a hole in the end which functions as a sample chamber, 55. When the threaded shaft is screwed in, the sample chamber comes in contact with the flowing fluid to be sampled. When the shaft is screwed out, a part of the flowing fluid is trapped. After evaporation of the excess untrapped sample from the chamber, the process is reversed and the shaft is screwed in. The sample chamber then comes in contact with carrier gas flowing to a gas chromatograph, the sample is vaporized by heating, and the analysis is completed.

Special care must be taken, because this sampler has no stop to prevent the threaded shaft from being completely withdrawn from the assembly while the body is under pressure.

Magnetic Pump

For successful pumping of small quantities of gases and liquids without leakage, a magnetic pump is desirable. Stein *et al.* (1962) used a Sterner magnetic pump (Sterner, 1960) to recirculate the gas phase in an equilibrium apparatus. In the present apparatus a suitable pump had to meet the following demands:

- One pump design for either gas or liquid service
- Self-priming
- Low holdup and minimal dead space
- Pressures up to 1000 p.s.i.a.
- Stainless steel construction with O-ring seals
- Small size
- Intermittent pulsing for low heat generation
- Submersible in a constant-temperature bath liquid
- Solid-state pulse generator for low maintenance

A modification of the Sterner pump (1960) was built and tested but proved to be too large and did not pump liquids easily.

Figure 3 shows the pump design which was developed to fill the present needs.

The basic components of the pump include two check valves, a piston, 101, and a pump bore, 104. The lower check valve is formed by check ball 102, which seals onto a seat in piston 101 when the piston is thrust upward. A second check valve is built into upper closure 106 (not shown in Figure 3). Lower closure 105 is similar to upper closure 106, but contains no check valve. During the operation of the pump an electrical pulse to solenoid coil 100 causes ferromagnetic piston 101 to be lifted upward in bore 104; this motion seats check ball 102 and carries fluid upward through the pump. At the end of the electrical pulse the magnetic field collapses, allowing piston 101 to fall by gravity down through bore 104. During this period the upper check valve seats to prevent backflow; fluid then enters the upper part of the pump through the coaxial hole in piston 101, which has been uncovered by the unseating of check ball 102.

The pump is self-priming and pumps either gases or liquids. However, it fails to pump a gas if the piston becomes so wet with liquid that the gravity fall of the piston is impeded.

The solid-state pulse generator for driving the pumps was designed so that the voltage, pulse width, and frequency of the pulse train could be varied independently.

Minimization of Dead Space

Minimization of dead space is important in order to attain equilibrium more rapidly and to facilitate meaningful sampling. The major sources of dead space relative to a recirculating stream exist where a tee connects the line to a sampling valve, to a control valve, to a rupture disk, or to a pressure-measuring device.

A special three-port valve (made to order by the Whitey Valve Co., Emeryville, Calif.) acts both as a tee and as a valve to control one of the three ports. Thus dead space in the usual connecting line between the tee and the valve is eliminated. The symbol used to represent the three-port valve is a circle with three entering lines and a cross within the circle on the controlled port (Figure 4).

A flush-diaphragm pressure transducer was used to minimize the dead space in the connecting line and in the pressure-measuring apparatus. The safety head was rebuilt in such a way that the recirculating gas stream flowed up through the head and out a port near the top just under the rupture disk.

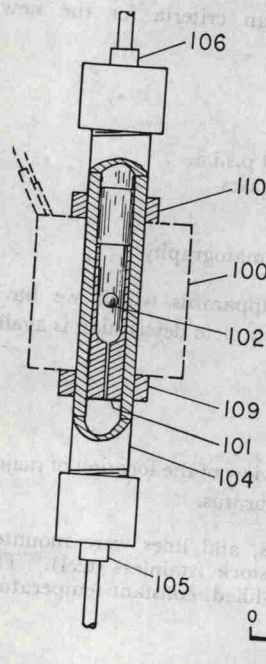

Figure 3. Magnetic pump

- 100. Solenoid coil
- 101. Piston (ferromagnetic)
- 102. Floating check ball
- 104. Pump bore
- 105. Lower cap
- 106. Upper cap
- 109. Lower collar
- 110. Upper collar

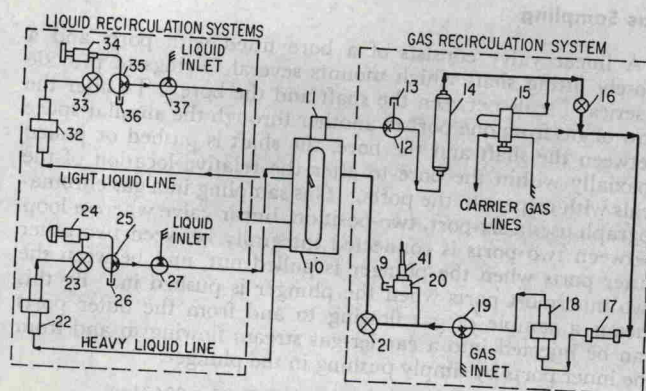

Figure 4. Gas and liquid recirculation systems